



Product Specification Sheet

Acclaim Fresnel



The Acclaim Fresnel is a 500W/650W general purpose luminaire (110mm diameter lens) for theatre, small studio and display lighting applications which produces an adjustable cone of light with a soft edge which is easily blended with adjacent beams to provide even illumination.

Built Selecon tough from aluminium extrusion and moulded engineering plastics – the Acclaim Fresnel is robust, dependable, safe and easy to rig and as with all Selecon luminaires backed by the unique Selecon 3-year warranty.

Features

Up to 40% more light output than comparative Fresnel luminaires.

A wide range of beam angles from 6°-60°.

Integrated safety bond, rated for the fitting; maximum free length = 650mm.

Improved filter life through increased airflow.

Cooler focus operation due to the use of engineering plastics on front (colour frame mount) and rear.

Adjustable yoke balance point.

'Swing-down' side door for easy access to lamp or for cleaning. Micro-switch automatically isolates the mains power supply when opened. Lamps are quickly and safely removed using ejector mechanism.

Lamp life is enhanced through judder-free focus action of the captive lamp/reflector assembly which moves on Teflon-coated bearings.

Heat-insulated rear grab-handle which doubles as handy storage for the 1m cable length.

New barndoor design, cool to focus maintaining settings through unique hinge tension design - retro-fittable.

Focusing is fast and safe using the large rear grab handle and heat protected focus knob and filter holder.

Lamps

500W T/25, T/18
11,000 lumens, 400hrs average life

500W M40
10,000 lumens, 2000hrs average life

650W T/26, T/27
14,500 lumens, 600hrs average life

Order codes

12ACFMS	Acclaim Fresnel
20BDMF	Barndoor
15ACSM	Lens safety mesh
20HC	Suspension hookclamp

Approvals

CE marked for use by all, not just professionals.



Photometric data

Tests conducted using a standard T27, 650W, 240V, 15,000 lumens lamp.

		Beam Diameter in m								
Beam angle	6 degrees	0	0.21	0.42	0.63	0.84	1.05	1.26	1.47	1.68
Beam angle	60 degrees	0	2.31	4.62	6.93	9.24	11.55	13.86	16.17	18.48
Throw distance in m		0	2	4	6	8	10	12	14	16
		Light Output in Lux								
Lamp										
240V T127 650W		Spot	18124	4531	2014	1133	725	503	370	-
		Flood	1872	468	208	117	75	-	-	-

Physical Data

Weight: 3.3kg.

Packed: 3.7kg.

Carton Size: 420 x 225 x 175.

Cubic: 0.016.

Colour frame size: 125mm x 125mm.

Luminaire with integrated safety bond supplied with: 1x colour frame, 1x M12 nut & bolt set and instruction leaflet.

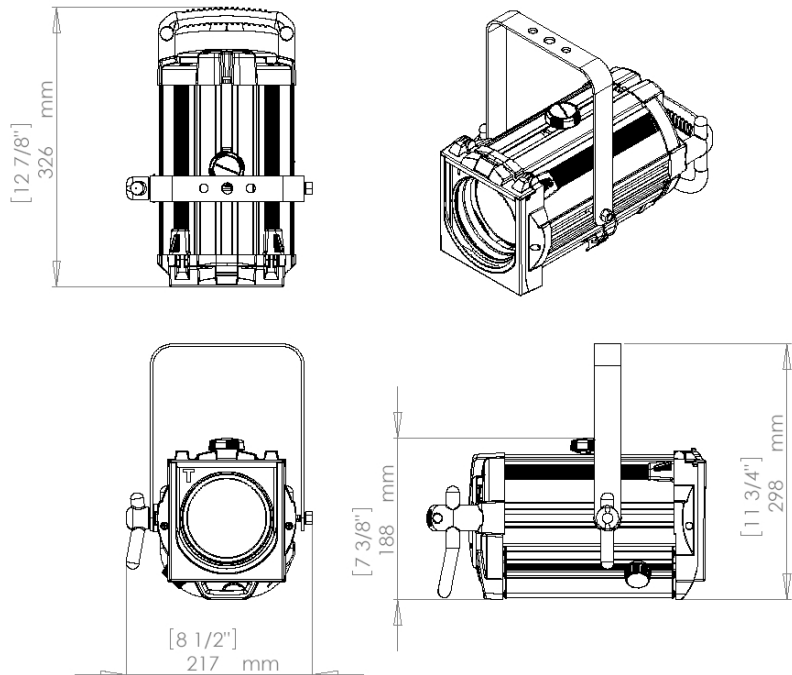

Selecon reserves the right to change the specifications without notice (September 2009).

PHILIPS
Entertainment