



# Product Specification Sheet

## Hui Flood



**Selecon's Acclaim and Aurora ranges have a well-deserved reputation for delivering filter life up to double of that of some cyc floods.**

**Further developments of our heat exhaust /control system has resulted in HUI delivering industry leading filter life for their class and size.**

Designed to withstand the most gruelling rental and production work.

Engineered from precision sheet metal and aluminium extrusions.

### Features

The HUI range uses either the 800W P2/11 lamp or the standard 300W K9 or 500W K1 THD lamps (118mm).

Make your own battens using the HUI slot lock joint system that allows a number of units to be locked together.

Makes a very effective groundrow. Simply reverse the colour cassette by removing the two screw pivot hinges. Add screw jack feet for adjustment. See separate HUI Groundrow specification sheet for conversion details.

Re-lamp without having to remove the filter or break focus.

Filter holder is held captive by spring hinged extruded cover that also blocks unwanted light spill.

One handed operation only required to focus, change filters etc.

Mains Power Disconnect – a microswitch isolates the mains supply when opening to re-lamp (phase and neutral) protecting against a student or technician inserting a lamp into a live socket.

Safety glass ensures that in the unlikely event of a lamp exploding that the remains are held captive within the luminaire.

Shape the beam and contain glare with the four-door barndoor accessory – fits all models.

### Lamps: 220V-240V

<b>800W P2/11</b> 24,000 lumens	150hrs average life
<b>500W K1</b> 9,900 lumens	2,000hrs average life
<b>300W K9</b> 5,600 lumens	2,000hrs average life
<b>200W K11</b> 3,520 lumens	2,000hrs average life

### Order Codes

<b>12HUIFLD1</b> HUI Flood 1 – maximum 800W
<b>12HUIFLD3</b> HUI Flood 3-way Batten – max 800W, cable tails
<b>12HUIFLD3G</b> HUI Flood 3-way Batten – max 800W, connector terminals
<b>12HUIFLD4</b> HUI Flood 4-way Batten – max 800W, cable tails
<b>12HUIFLD4G</b> HUI Flood 4-way Batten – max 800W, connector terminals
<b>15HLGDSF</b> Groundrow screw jack feet (set of 2)
<b>15HUIBD</b> Barndoor – 4 leaf
<b>15HLJ</b> Joiner set (2 of) slot locks
<b>15HLCF</b> Spare colour frame

### Approvals

Fully tested and compliant to CE standards.



## Photometric Data

Tests conducted using standard R7 118mm double-ended linear lamps: 500W & 800W 240V.

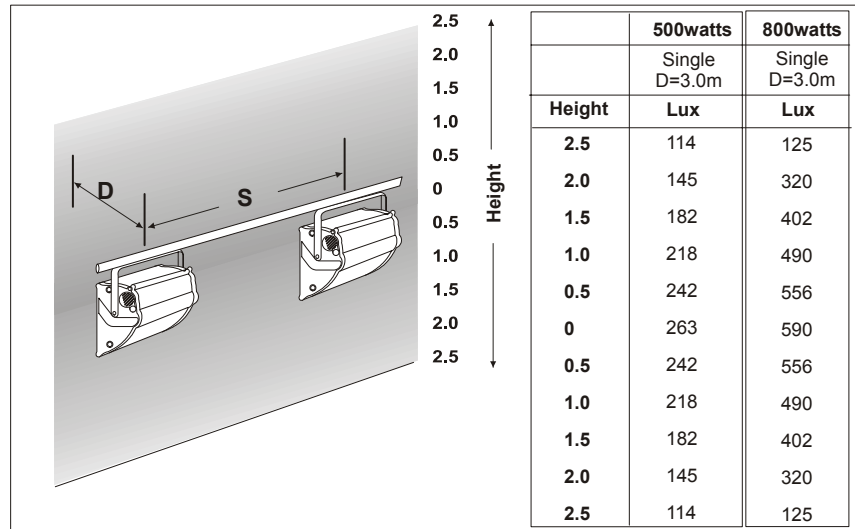

## Physical Data

	Single	3-way	4-way
<b>Weight:</b>	4.1kg	10.7kg	14kg

**Colour frame size:** 265mm x 203mm

**Included:** 1x colour frame per cell, 1x M12 suspension bolt set and instruction leaflet.

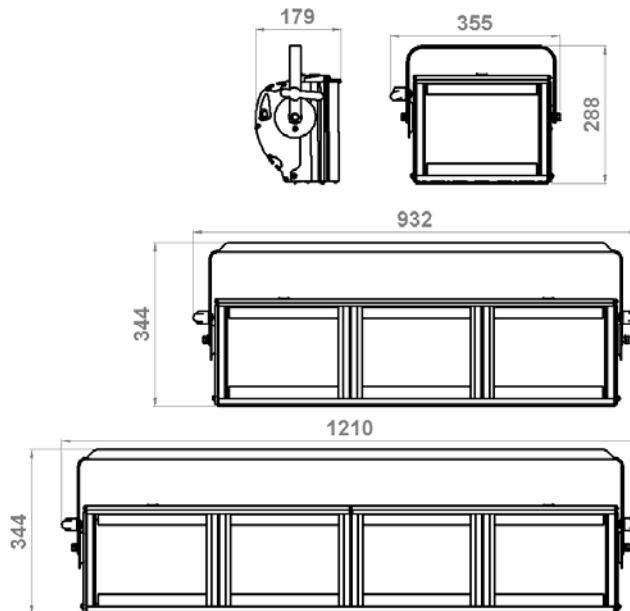



---

## Connector Panels and Options

---

With the connector options to suit your needs:

### **Standard**

Separate silicon rubber cable tails, with protected entry and clamping gland.

### **Connector Model**

Comes fitted with terminal box to which you wire your connector requirements.

### **Connector boxes**

Mounted beside the termination box with wiring running through side panel knock outs for - multi connectors, cable tails, socket outlets - to fully utilise multi core cable circuit capacity.

### **Standard Connector Mounting options include:**

2 x 32mm cable glands fitted to the terminal box cover plate – supplied as standard.

19 pin Socapex Mount Box (connector not supplied).

Order Code: 15HLCS

10 pin Wieland Mount Box (connector not supplied).

Order Code: 15HLCW10

16 pin Wieland Mount Box (connector not supplied).

Order Code: 15HLCW16

15A UK type Socket Outlet Mount Box (required for Spec of outlet – not supplied).

Order Code: 15HLCAUK

10A Aust/NZ 10A Socket Outlet Mount Box (PDL type 40 – supplied).

Order Code: 15HLCANZ

3 and 4 flexible cable tail termination boxes c/w cables.

Order Codes:

3 circuit – 15HLC3F

4 circuit – 15HLC4F

---

Selecon reserves the right to change the specifications without notice (September 2009).