



Product Specification Sheet

Aurora Flood



A 1.0kW / 1.25kW symmetric flood luminaire for larger theatres and studios and general purpose display lighting.

Features

90° light beam is smooth and falls off evenly without visible high lights or shadows.

The extruded aluminium reflector guarantees repeatability of beam characteristics.

Robust construction from a combination of aluminium extrusions and formed steel panels.

Filter life is maximised by the dual air-flow chamber construction.

Filter frame size ensures an economic two frame cut out of a standard filter sheet.

The filter frame is flat ensuring it can be mounted into the luminaire with ease.

Re-lamp without removing the colour filter holder via the hinged front filter holder assembly.

Barndoor accessory available for beam masking.

Available configurations: single, with or without pole operated tilt; multi batten options as per the Aurora Cyc.

Lamps: 220V-240V

P2/12 1250W
33,750 lumens 200 hours average life

P2/7 1000W
26,000 lumens 200 hours average life

P2/10 625W
16,250 lumens 200 hours average life

Order codes

10AUFLD
Aurora Flood

10AUFLDPO
Aurora Flood with pole operation

10AUFLD4L
Aurora 4-way Linear Flood with cable tails

20DBAU
Aurora Barndoor

20HC
Suspension Hookclamp

20SC
Safety Bond

Approvals

Compliant to CE standards.



Photometric data

Tests conducted using a standard 1250W, 240V, 189mm P2/12 lamp.

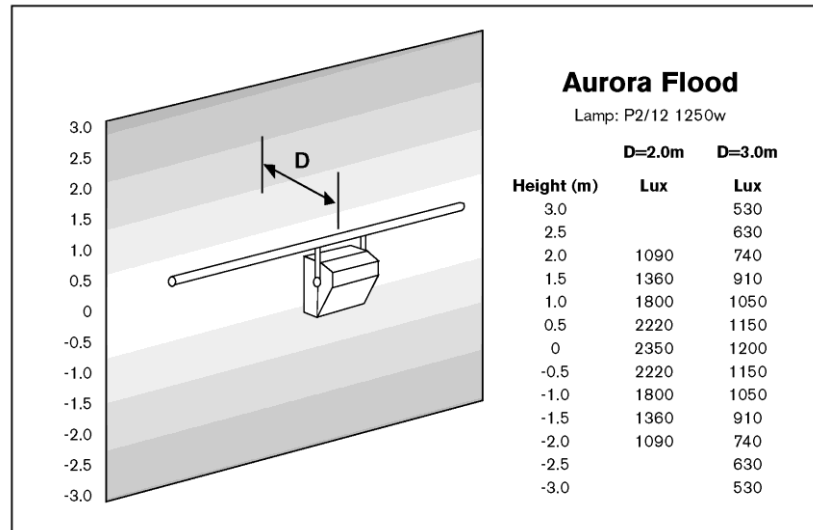

Physical data

Weight: 10.2kg

Packed weight: 11.4kg

Cubic: 0.073

Colour frame size: 305mm x 315mm

Included: 1x colour frame for single, 1 x M12 nut & bolt set, instruction sheet.

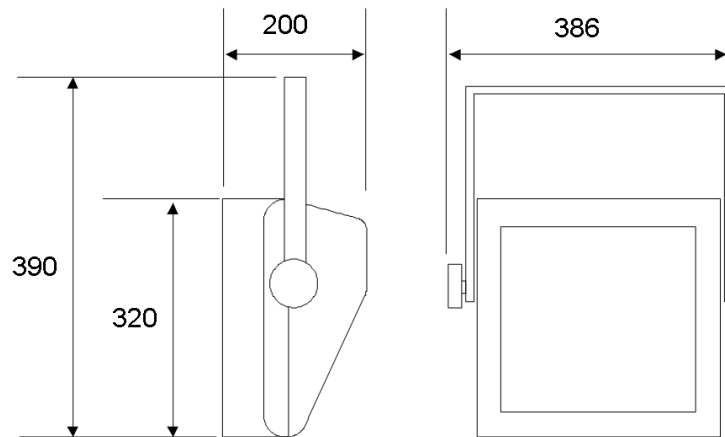

Selecon reserves the right to change the specifications without notice (November 2009).